



Designed for heat pumps

DHW tanks with two high efficiency coils with large heating surface

INDEX	FISH S16 300 X	693 220 300
	FISH S16 400 X	693 220 400
	FISH S16 500 X	693 220 500

Domestic hot water storage tanks in an standing version for domestic hot water preparation. The tank has 2 large surface coils, the upper one is designed for a heat pump and the lower one for a solar system or a boiler. The contact surface of the hot water tank is protected against corrosion with a high quality enamel coating and 2 magnesium anodes*. In accordance with DIN 4753, this ensures that the drinking water only comes into contact with a hygienically clean surface.

Thermal insulation

Thermal insulation in the tanks is a layer of permanently bonded CFC-free polyurethane hard foam and a replaceable layer of PVC foil.

Standard equipment

Inspection opening, thermometer, electric heater socket, 2 magnesium anodes*, internal coil.

*Optionally a titanium anode can be used.

Technical description

- › Material: **S235JR**
- › Welding: **automatic** welding
- › Protection: **high-quality** enamel coating and 2 protective anode
- › Maximum operating pressure of the tank: **10 bar**
- › Maximum test pressure: **15 bar**
- › Maximum operating temperature: **95°C**
- › Insulation: **50mm** thick polyurethane foam
- › Outer jacket: color **gray**
- › Heat exchangers: steel pipe **P235GH**
- › Inspection opening: **ø122mm/ø179mm**

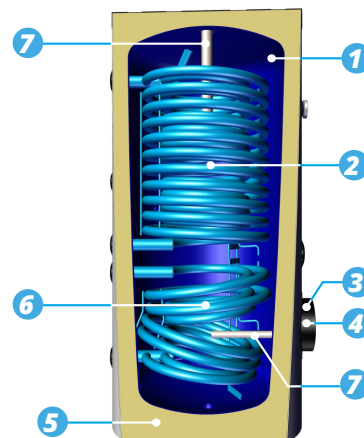

- 1 High-quality enamel** for reliable corrosion protection
- 2 High efficiency coil** with increased surface area for heat pumps
- 3 Connection socket** for mounting a dedicated **UV-20 disinfection system**
- 4 Inspection opening** for easy cleaning, possibility to install a heater
- 5 PUR foam insulation** for **excellent thermal insulation**
- 6 High efficiency solar system coil**
- 7 Protective magnesium anode** for corrosion protection

			WT1	WT2	WT1	WT2	WT1	WT2
Capacity	L		300		400		500	
Coefficient of performance N_e			11	16,4	15	22,7	19	29,6
Constant performance* (80/10/45)**	kW		39	72	50	85	56	103
Constant performance* (80/10/45)**	l/h		960	1770	1230	2090	1370	2530
Max. permissible temp. (tank/coil)	°C		95/110		95/110		95/110	
Max. permissible pressure (tank/coil)	bar		10/16		10/16		10/16	
Heat exchanger capacity	l		6,6	14,8	8,5	14,8	10,2	24,7
Heat exchanger surface	m ²		1,2	2,6	1,6	3,3	1,8	4,4
Insulation	mm		50		50		50	
Diameter with insulation	D	mm	657		757		757	
Tank diameter (without insulation)	P	mm	550		650		650	
Height/diagonal	H	mm	1462/1557		1502/1637		1783/1891	
Water drain	h1	mm	74		74		74	
Cold water	h2	mm	272		294		295	
Additional heat source (return)	h3	mm	276		306		311	
DHW sensor	h4	mm	569		616		722	
Additional heat source (supply)	h5	mm	547		616		664	
Heat pump (return)	h6	mm	665		711		760	
DHW sensor	h7	mm	795		854		1082	
Circulation	h8	mm	884		1051		1264	
DHW sensor	h9	mm	1032		1154		1442	
Heat pump (supply)	h10	mm	1233		1241		1531	
Warm water	h11	mm	1233		1251		1531	
Magnesium anode	h12	mm	1434		1477		1756	
Thermometer	h13	mm	1138		1196		1386	
Electric heater	h14	mm	634		679		712	
Heater socket	h15	mm	402		436		436	
Inspection hole	h16	mm	387		421		421	
Magnesium anode	h17	mm	352		386		386	
Connections								
Cold water/hot water	h2/h11	G	1 1/1"		1 1/1"		1 1/1"	
Circulation	h8	G	3/4"		3/4"		3/4"	
Heat pump (supply/return)	h10/h6	G	1 1/1"		1 1/1"		1 1/1"	
Additional heat source (supply/return)	h5/h3	G	1 1/1"		1 1/1"		1 1/1"	
Inspection opening	h16	mm	122/179		122/179		122/179	
DHW sensor	h4/h7/h9	G	1/2"		1/2"		1/2"	
Thermometer	h13	G	1/2"		1/2"		1/2"	
Anode	h12	G	1 1/2"		1 1/2"		1 1/2"	
Anode	h17		M8		M8		M8	
Electric heater/Heater socket	h14/h15	G	1 1/2"		1 1/2"		1 1/2"	
Water drain	h1	G	1 1/2"		1 1/2"		1 1/2"	
Weight (empty)		kg	160		220		269	

G - internal thread type G

WT1 - bottom coil, WT2 - top coil

* at heating medium flow rate 2,5 m³/h

**80/10/45 - (heating medium inlet temperature/ supply water temperature/ DHW temperature)

